

**Product Information:**

- Bench with 250mm wide rubber scrape hole
- 1.2mm thick 304 stainless steel top
- Stainless steel top hat stiffening
- 38mm diameter round stainless steel tube legs, 1.2mm thick with adjustable disk feet
- Supplied with leg brace as standard, for rubbish bin to sit underneath bench
- 100mm splashback (600 series) or 150mm splashback with beveled edge (700 series)
- Vermin proofing included behind upstand with pre-drilled holes for fixing bench to rear wall
- Supplied flat packed ready for assembly

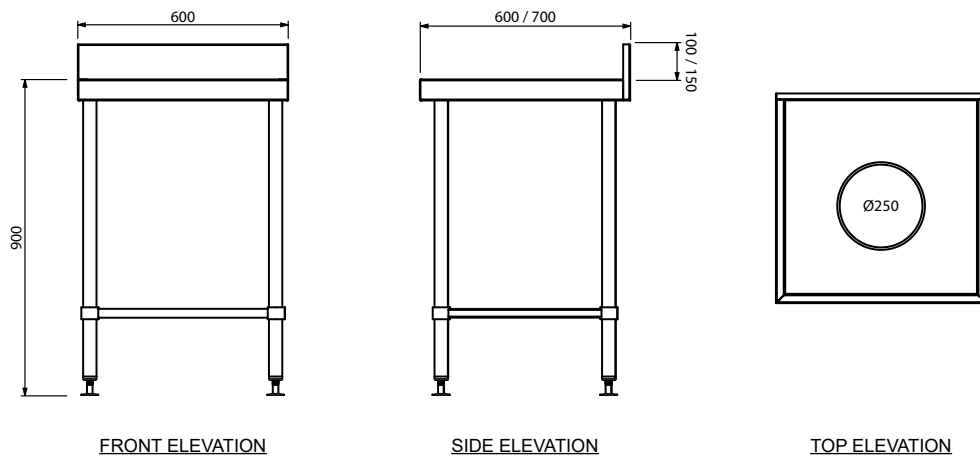

**General Drawing:**



**Specifications:**

**SS05.SH.0600**      600mm x 600mm x 900mm

**SS05.SH.7.0600**      600mm x 700mm x 900mm